

ERP-VL CRITICAL COMPONENTS

Tough, industrial applications require industrial grade lift trucks that add productive value: operate at maximum uptime, perform at demanding performance levels, and require minimal cost to operate. **Yale® ERP-VL** lift trucks are designed and built with Industrial Grade Critical Components, providing outstanding productive value and economic life. It's a difference you can count on.

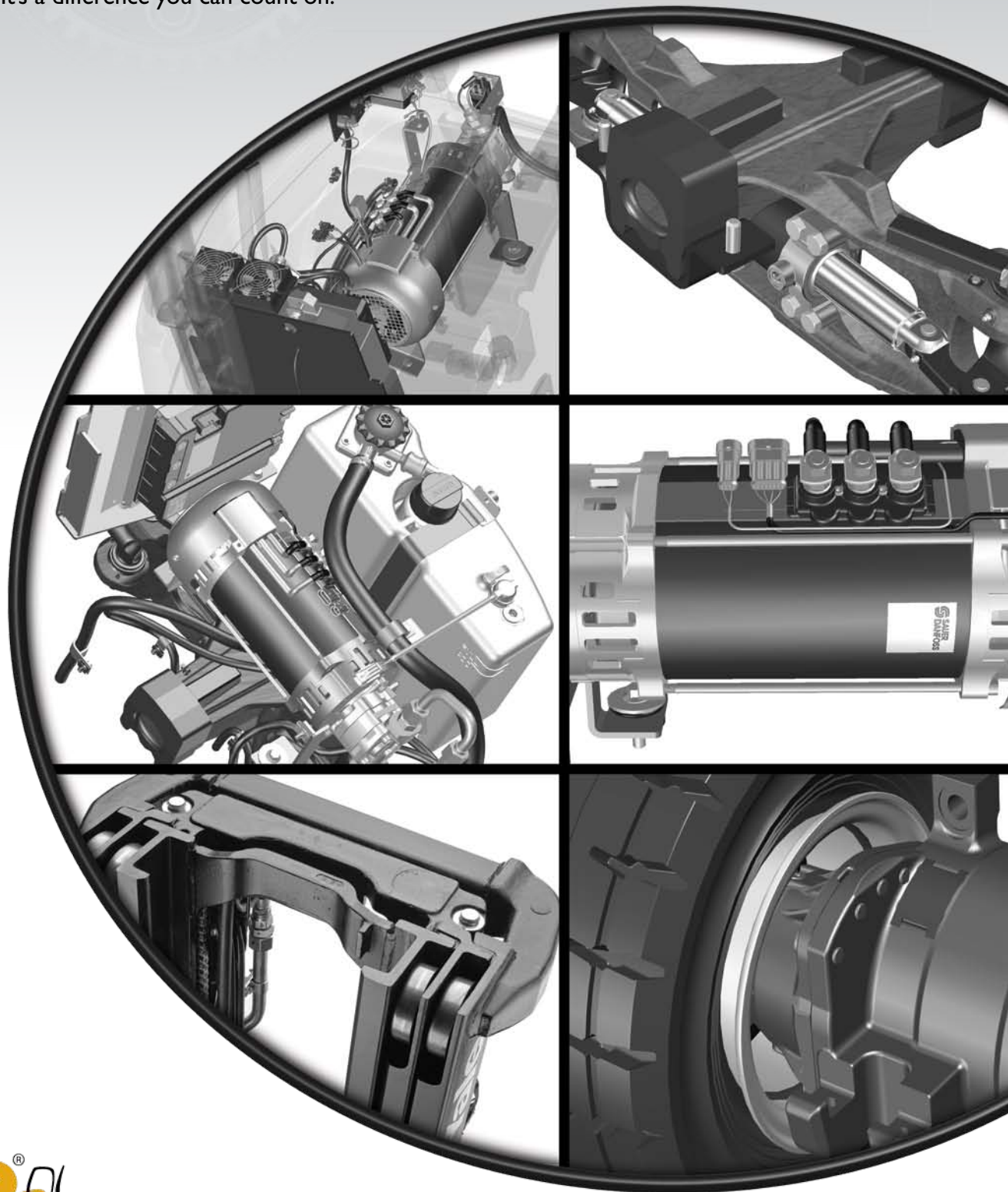

ERP-VL CRITICAL COMPONENTS

Motors

Electric motors ensure the lift truck travels and lifts at speeds required for maximum productivity and throughput. AC motors eliminate brushes, significantly reducing maintenance costs. Steering motor functionality is integrated into the hydraulic motor, simplifying the system and increasing reliability. Motors are insulated with Class H insulation for superior heat resistance. Dual drive motors enable a tighter turning radius, improving maneuverability and productivity.

Drive Axle

The drive axle of a lift truck is required to absorb significant forces during normal operation, as well as support the weight of the mast and load. High strength gears and shafts resist stress from quick directional changes. The tough cast housing absorbs shock and vibration. Wet disc brakes virtually eliminate brake maintenance, while power assisted braking reduces strain on drive unit components.

Electrical System

Linking the electronic components of a lift truck together for efficient operation, the electrical system must be durable and reliable for the toughest applications. CANbus technology reduces wiring and connections, improving system reliability. Sealed electrical connections resist moisture and dirt, increasing uptime. The innovative thermal management system protects key components, while ensuring maximum productivity.

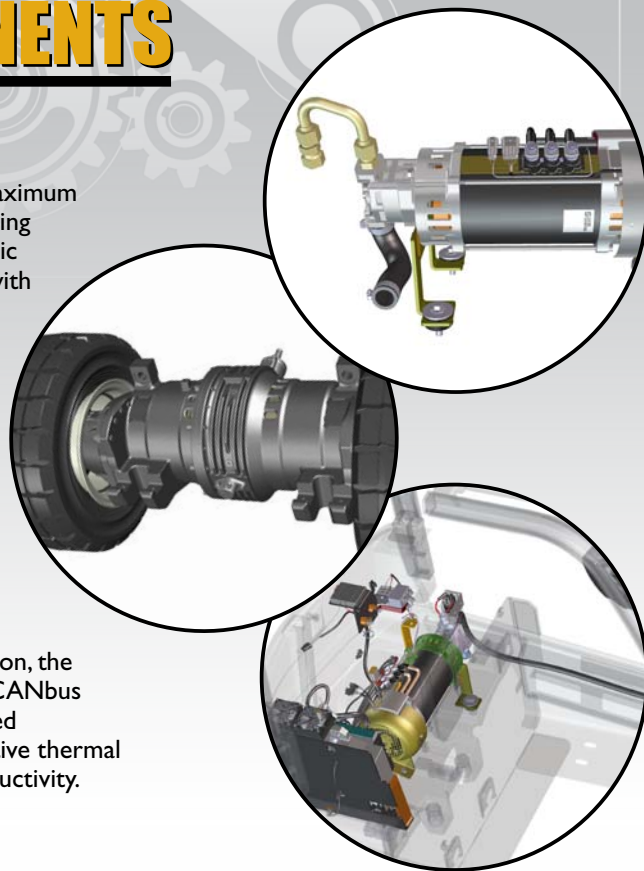

Hydraulics

Hydraulics are the “muscles” of a lift truck, providing the force necessary to lift heavy loads all shift long. O-ring face seal fittings resist leaks. A 10 micron hydraulic filter helps keep the hydraulic fluid clean, improving system reliability. Cast iron “stacked” valve sections provide both excellent rigidity and exceptional serviceability.

Steer Axle

Steer axles absorb a lot of punishment during a lift truck operation cycle, as they support the significant weight of the counterweight while being subjected to road shocks and vibration. Tough cast ductile iron axles provide one piece integrity for outstanding durability. Tapered roller bearings absorb multiple loading forces, improving reliability while simplifying the design. The “Continuous Stability Enhancement” system enhances truck stability in a simple, maintenance free design, without compromising uneven surface travel. The innovative “Zero Turn Radius” design provides enhanced maneuverability.

Mast

A lift truck’s mast is required to absorb significant stress during lifting and lowering operations, without incurring excessive maintenance downtime. Canted load rollers absorb front to back and side-to-side forces for better durability and reduced adjustments. Full-face contact of rollers prevents excessive wear of the channel, prolonging roller life. Rolled steel mast channels provide excellent stress distribution and durability.

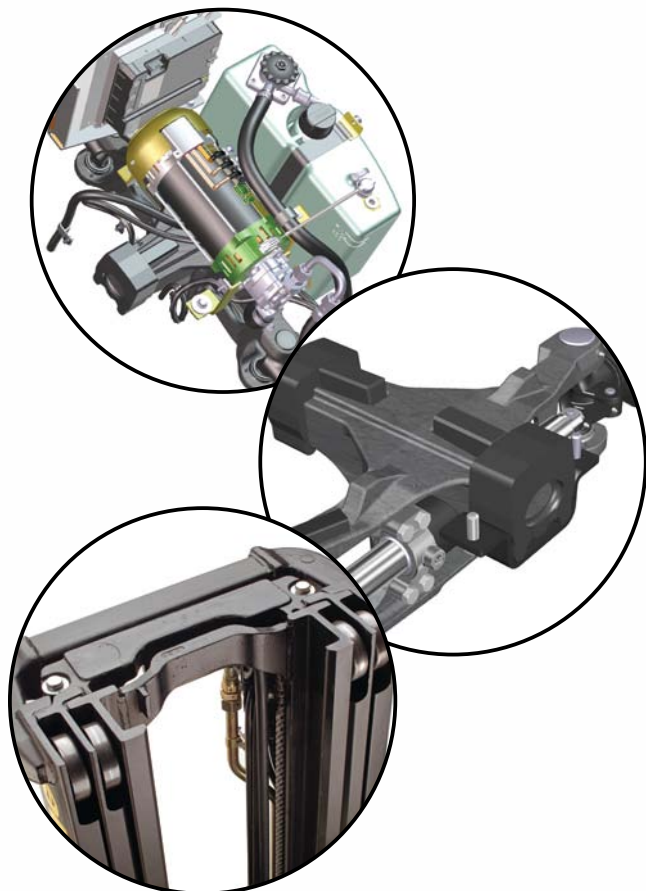

Yale Materials Handling Corporation

P.O. Box 7367, Greenville, NC 27835-7367 • © 2009, Yale Materials Handling Corporation • www.yale.com

Yale and  are trademarks or registered trademarks of Yale Materials Handling Corporation in the United States and other countries. 2113-2 09/09